

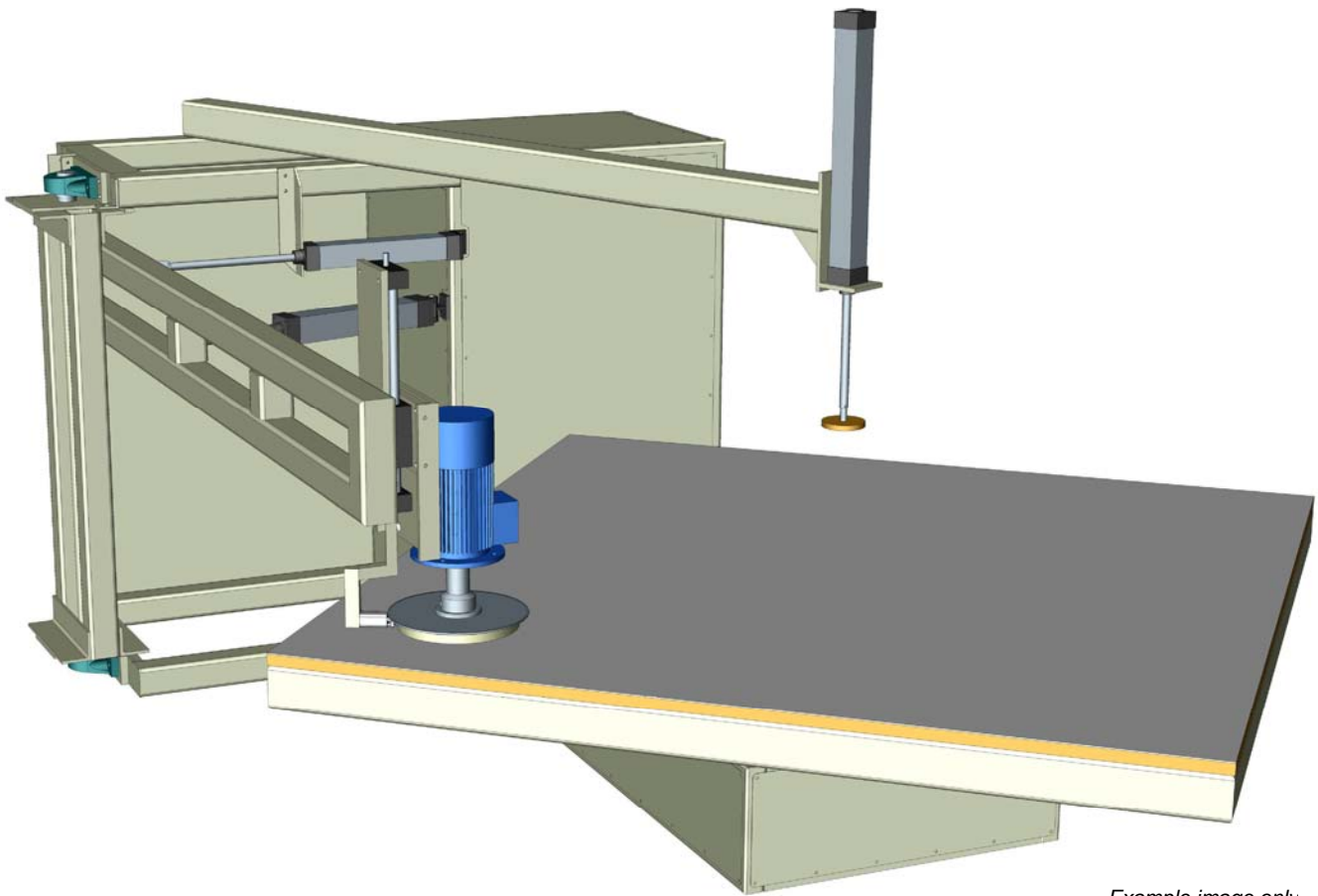

ARMOUR

~ engineering for plastics

**AT-1 1-06
AUTO-TRIMMING MACHINE**



Example image only

The AT-11 Auto-Trimming Machine is designed to trim products reliably and economically. Products are held in position on the machine bed using a pneumatic system that allows quick and easy loading and unloading of products. The machine automatically follows the profile of the product. No Programming is required. Machine enclosures and dust extraction systems are available to order.

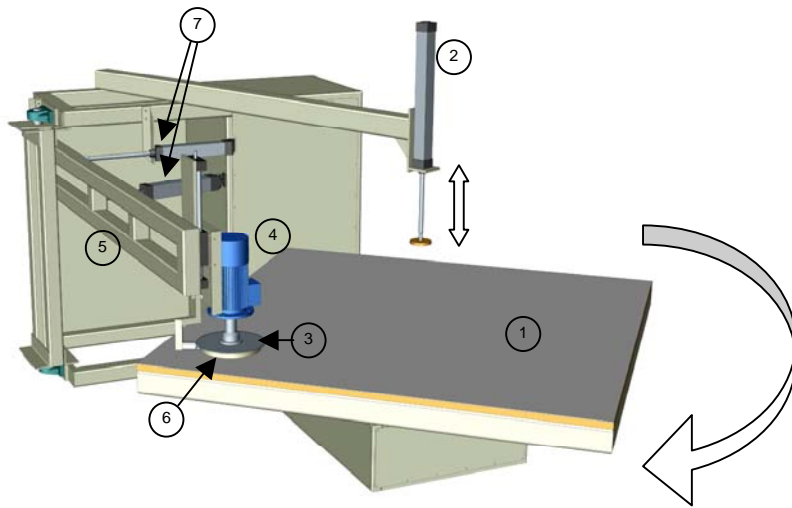

1. Rubber covered product table
2. Product clamping cylinder
3. Cutting blade
4. Cutting motor
5. Arm
6. Guide wheel
7. Arm movement cylinders

When the Operator presses the start button the product is held down on the rubber covered table (1) by the clamping cylinder (2). The cutting blade (3), mounted on the cutting motor (4) starts to rotate and the arm (5) moves the blade in until the guide wheel (6) runs around the edge of the product. The table then makes one complete revolution and so the product is trimmed. When the trim is completed the arm moves back to the rest position by means of the movement cylinders (7) and the cutting motor switches off. The product can then be removed from the machine.

MACHINE SPECIFICATION

ELEMENT	SPECIFICATION
Machine Capabilities	Maximum product size: 2000 x 2000 x 550mm Minimum trim height: 25mm Maximum trim height: 200mm Cutting time: 120 seconds Total cycle time: 135 seconds
Machine Construction	Main frame: Rolled steel sections – BS EN 10025 material Casing: Sheet steel – BS EN 10025 material Paint finish: Textured powder coating
Cutting Head	Blade: 400mm diameter tungsten carbide Cutting speed: 2820 rpm Cutting motor power: 2.2 kW A guide wheel under the blade follows the product profile.
Turntable Movement	Directly driven by electric motor and gearbox. Drive motor power: 0.12 kW Rotation speed: 0.5 rpm
Product Holding	Pneumatic clamp and high-grip rubber tabletop.

Control System	PLC controlled sequence using electrical sensors. Trim height adjusted manually.
Dust Extraction	Particle removal via a separately supplied blade shroud and extraction unit.
Enclosure	Modular unit with sliding door recommended. Specified and supplied separately.
Compressed Air	Minimum pressure: 5.5 Bar Maximum flow required: 210 litres/min Air consumption per cycle: 30 litres
Electricity	3 Phase supply + Neutral + Earth: 380/415V @ 50Hz Maximum power consumption: 3kW

example specification only - specification may be subject to change without notice

For further information contact

Armour Plastics Limited

Engineering Division

Pattinson Industrial Estate

Washington, Tyne & Wear, NE38 8QH, England

Telephone: +44 (0)191 416 7786 Fax: +44 (0)191 416 7109

sales@armour-engineering.com

www.armour-engineering.com