

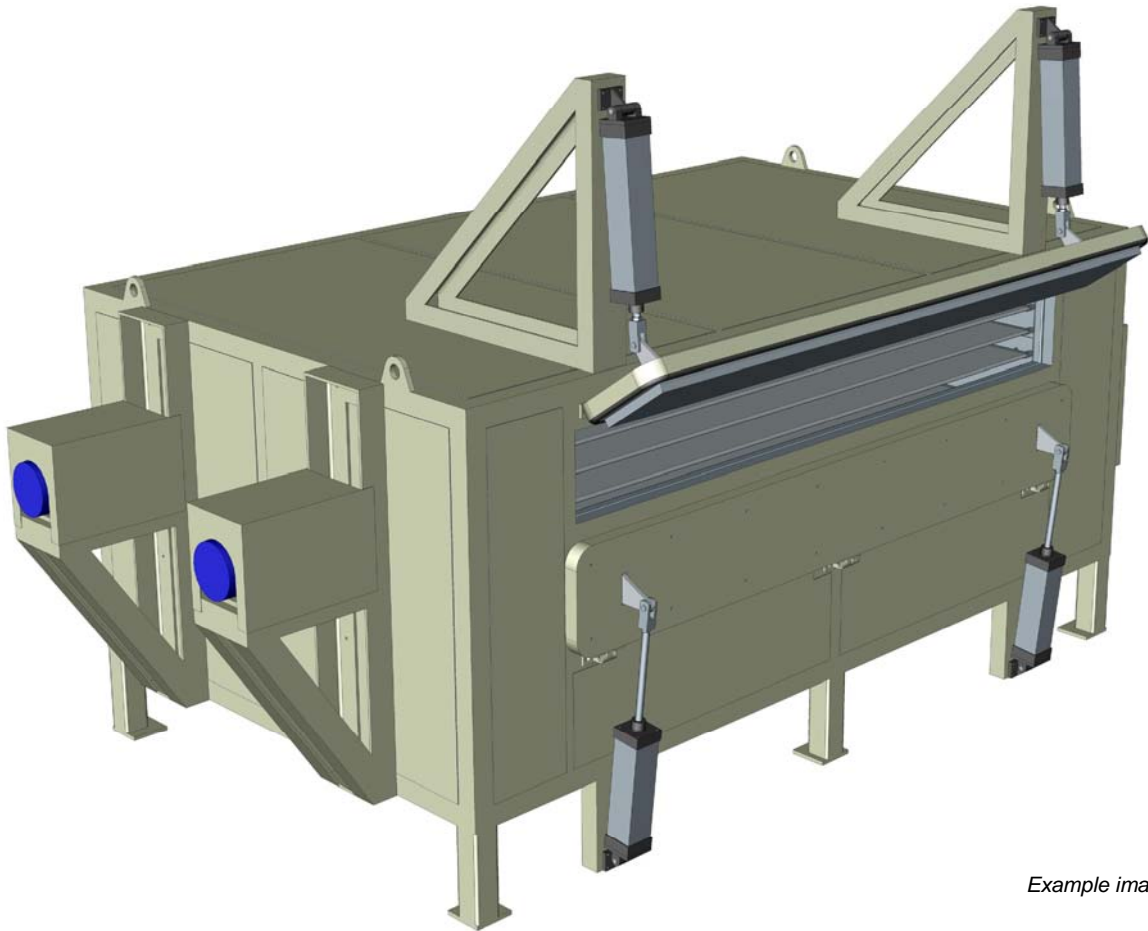

ARMOUR

~ engineering for plastics

**SSO-06-06
STATIC SHELF OVEN**



Example image only

The SSO Static Shelf Oven is built for heating acrylic sheet for vacuum forming applications. With the addition of Teflon coated shelves other materials can also be heated, including ABS & HIPS. The design provides superior heat insulation and near perfect heat distribution for economical, high quality production.

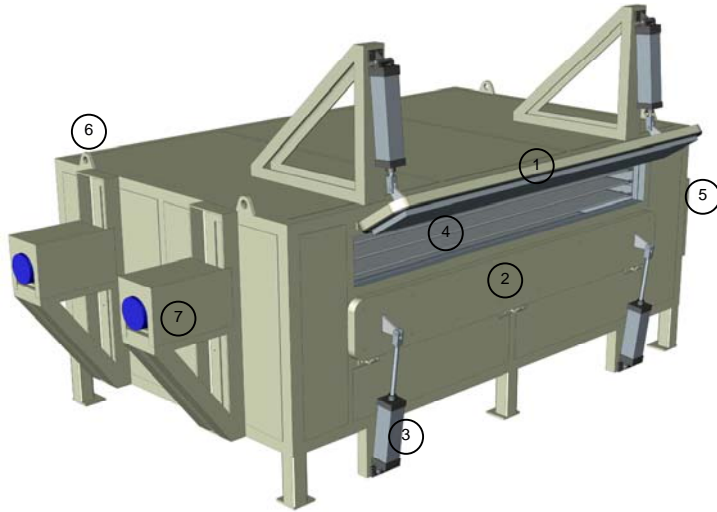

1. Upper load/unload door
2. Lower load/unload door
3. Door cylinders
4. Sheet shelves
5. Heating element cover
6. Lifting eyes
7. Circulation fans

The oven heating can be specified as either electrical elements (5) or indirect gas burner. The air circulation is by motor driven fan (7). The PLC control system incorporates a timer so that operating temperature is achieved in readiness for the start of the working day. The doors are opened and closed by pneumatic cylinders (3) to provide a reliable seal. The Operator actuates the cylinders with a pair of foot switches. This ensures that hands are kept free to load/unload the plastic sheets from the aluminium shelves (4). Temperature is set by the operator and is constantly monitored & controlled for accuracy. A timer with alarm notifies the Operator when the sheet is ready for removal from the oven. Armour Static Shelf Ovens are available in many size and specification configurations.

MACHINE SPECIFICATION

ELEMENT	SPECIFICATION	
Machine Capabilities	Maximum sheet size: Number of shelves:	3000 x 2000mm 6
Machine Construction	Main frame: Casing: Size: Paint finish:	Rolled steel sections – BS EN 10025 material Sheet steel – BS EN 10025 material Width 4.9m – Depth 2.4m – Height 2.8m External textured powder coating Internal high temperature aluminium
Shelves	Size: Material:	3050 x 2000mm Aluminium
Doors	Removable for cleaning. Teflon coating optional.	
Heating	Pneumatically operated via footswitches. 2 doors, each opening to 3 shelves.	
	Incoloy heating elements.	
	Quantity: Heating power:	21 3kW each

Control System	PLC controlled sequence. Electronic temperature controller. Sheet timers with audible alarm. Normal service temperature: 180°C Maximum temperature: 250°C Control accuracy: ±2%
Air circulation	Twin fans Fan motor power: 2.2kW Speed: 1420 rpm
Compressed Air	Minimum pressure: 5.5 Bar Maximum flow required: 840 litres/min Air consumption per cycle: 70 litres Required air supply quality: Dried and filtered
Electricity	3 Phase supply + Neutral + Earth: 380/415V @ 50Hz Maximum power consumption: 70kW
<i>example specification only - specification may be subject to change without notice</i>	

For further information contact

Armour Plastics Limited
 Engineering Division
 Pattinson Industrial Estate
 Washington, Tyne & Wear, NE38 8QH, England

Telephone: +44 (0)191 416 7786 Fax: +44 (0)191 416 7109

www.armour-engineering.com