

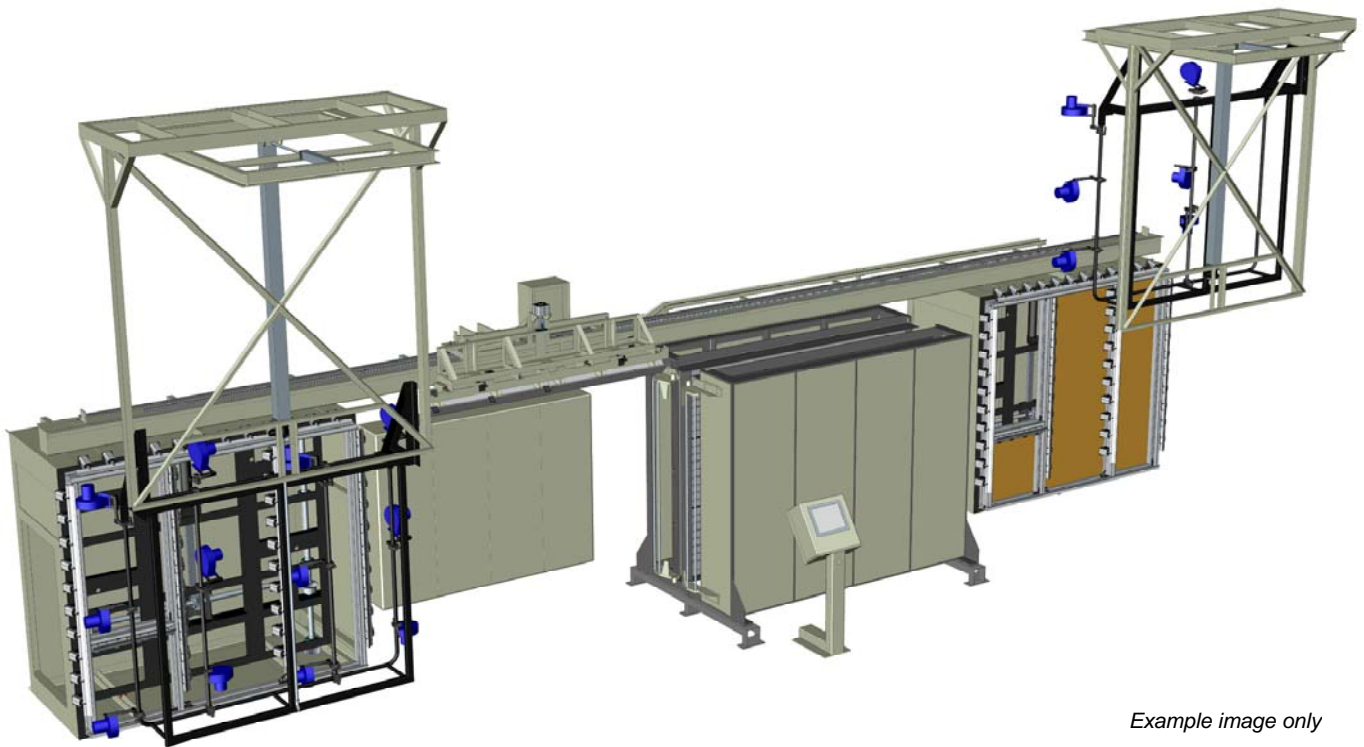

ARMOUR

~ engineering for plastics

VT-22-06 VERTICAL THERMOFORMER



Example image only

The VT-22 Vertical Thermoforming System is designed to give the fastest possible cycle times available with vacuum forming machinery. This is achieved by operating the heating process and the forming process simultaneously. An optional second station (as shown above) allows continuous production as mould set-up can be carried out on one station whilst forming is running on the other. Optional water heaters for mould heating and integral cranes for mould changes at each station are available. Other options include automatic sheet cleaning bars, sealed cabinet for pressurised moulding and mould temperature control.

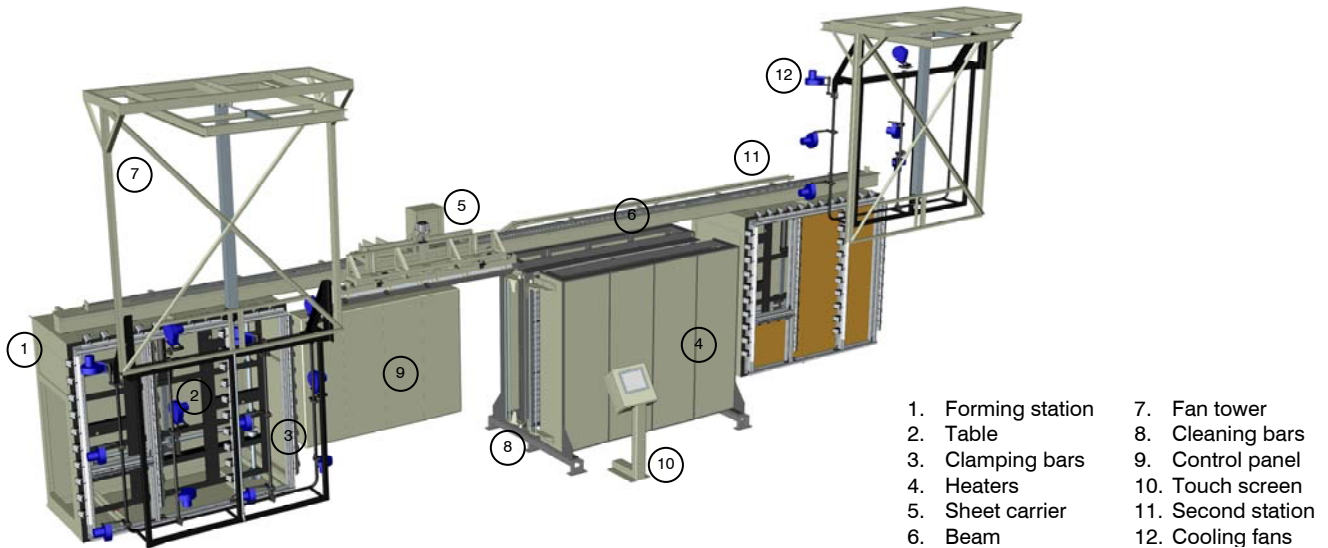

- | | |
|--------------------|--------------------|
| 1. Forming station | 7. Fan tower |
| 2. Table | 8. Cleaning bars |
| 3. Clamping bars | 9. Control panel |
| 4. Heaters | 10. Touch screen |
| 5. Sheet carrier | 11. Second station |
| 6. Beam | 12. Cooling fans |

Sheets are loaded into the sheet carrier (5) that moves the sheet between the different parts of the machine. The beam (6) provides the track that the sheet carrier travels on, and it runs the full length of the machine. This enables the sheet to travel from the load position, into the heaters, and then to either of the two forming stations. The heaters (4) are mounted in two banks, front and back, for dual sided heating. Two pyrometers are fitted to the machine that monitor the actual sheet temperature in the heaters. When the sheet has reached its forming temperature it is carried to the selected forming station (1 or 11), where the sheet is released and held in the clamping bars (3) for the forming process. At this point the sheet carrier returns to the loading position where the next cycle can begin immediately. Moulds are fixed to the table (2), which controls the penetration into the plastic sheet. The fan tower (7) is mounted above and directly in front of each forming station. A frame carrying the cooling fans (12) moves down during the cooling cycle only.

The Armour clamping bars have been specially designed for ease of set-up and fast tool changes. Each clamping bar is comprised of two high precision aluminium extrusions, a fixed bar (1) and a hinging clamping bar (2), which is actuated via a series of pneumatic cylinders (3). The size of the forming aperture can be varied by moving the main sliding bar (4) and the adjustable bar (5). Both of these are mounted on linear guides (6), and slide on high precision rails (7), and are locked in position with a locking handle (8). The forming length is infinitely adjustable along the slide. The forming width requires loose pieces to make up any gap (9) between the two adjustable bars. These can be easily fitted and are bolted in place using a steel brace.

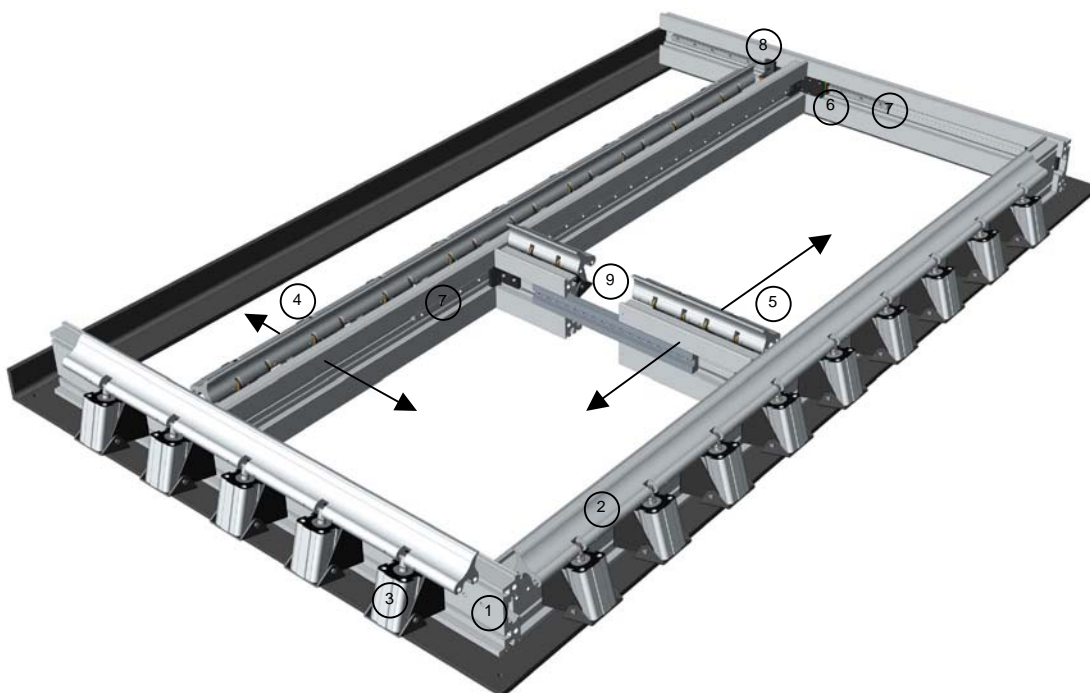

It is critical to the forming process that the progression of the mould into the sheet is smooth and controlled. Armour mould tables run on precision linear guides and rails, and are driven with hydraulic cylinders through large rack and pinion drive gears. Each machine is supplied with a self-contained hydraulic power pack incorporating an electrically driven hydraulic pump and oil reservoir, with solenoid valves controlling the cylinder movement. Variable table speed systems are also available as an option.

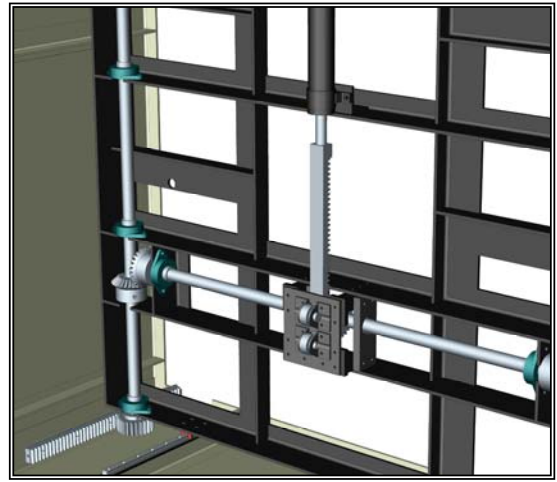

The heater banks consist of a series of quartz infrared heating elements, adjustable in pairs (one front heater and one back heater) to allow complex heating patterns to be used. These heaters have a rapid response time and therefore energy is saved between cycles when the heaters drop to a very low standby power. The acrylic sheet is only held by the top edge during the heating process, thus ensuring that no stress is induced (a common problem when clamping cold sheet), and therefore straighter products can be produced without warping.

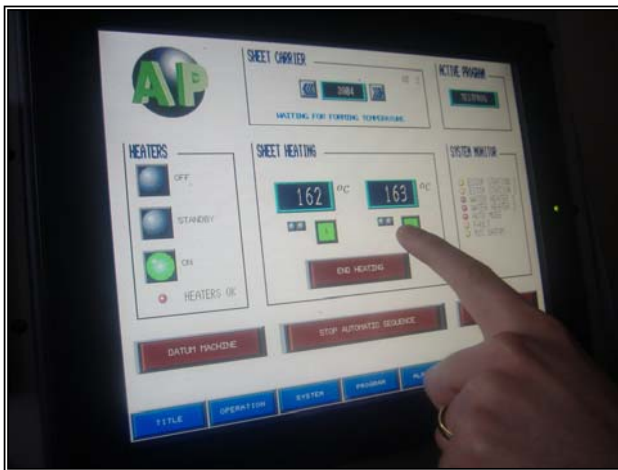

Armour control systems use a Mitsubishi PLC to control the sequencing of the machine, and have a Proface touch screen as the user interface. Up to 1000 programs can be created and are stored on a Compact Flash card, allowing easy backup. Reporting facilities are available and .csv files can be exported for offline production analysis. The system is fitted with a modem to allow remote access by Armour Engineers for diagnostic checks and software upgrades. All machine software is written by Armour and therefore new versions and additional features can be developed.

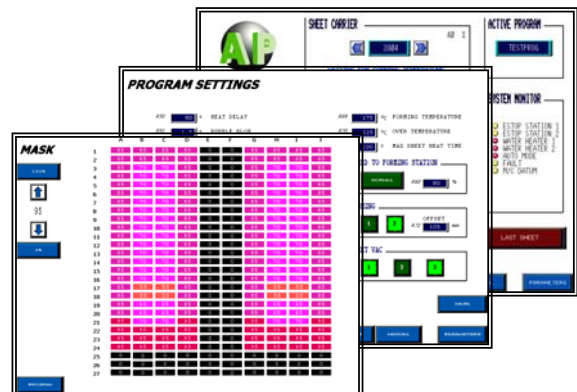

VERTICAL FORMING MACHINE BENEFITS

Performance:

The speed of the Vertical machine gives a higher output than any other machine available - 36 products per hour (18 cycles per hour with 2 moulds, 4mm cast acrylic & aluminium moulds). This is much greater than the usual 10 – 14 products per hour achieved on standard machines

Product Quality:

The product quality is the highest possible for the following reasons:-

- The vertical position of the moulds ensures that they stay clean and therefore no marks will be present in the formed part
- The acrylic sheet is only held by the top edge during the heating process and therefore no stress will be induced by clamping cold sheet, and this gives a straighter product with no warping
- Electrostatic sheet cleaning bars that automatically clean every sheet with electro-charged compressed air, prior to heating.

Man-power & Skill level:

The Vertical machine is extremely easy to use, and can be operated with only 1 man to achieve 36 products per hour. This is a significant saving in labour costs compared to horizontal equipment.

Tool change time:

Mould changes can generally be accomplished in less than 10 minutes.

Machine Cost:

The price of a Vertical machine is not much higher than an Armour Horizontal machine and much lower than the cost of our major European competitors.

Conclusion:

For a sanitary ware producer, no other machine available offers such an incredible level of performance, and the price ensures that it is affordable.

MACHINE SPECIFICATION

ELEMENT	SPECIFICATION
Machine Capabilities	Maximum product size: 2000 x 2000mm Maximum forming aperture: 2014 x 2014mm Minimum forming aperture: 711 x 500mm Maximum tool height: 840mm Maximum tool push through: 600mm Maximum sheet thickness: 8mm Cycles per hour (4mm cast acrylic): 18 cycles Output (2 aluminium moulds & 4mm cast acrylic): 36 products per hour
Machine Construction	Main frame: Rolled steel sections – BS EN 10025 material Casing: Sheet steel – BS EN 10025 material Paint finish: Textured powder coating
Clamping Bars	Material: Extruded aluminium profile – Armour design Adjustment: By precision linear slides & make up pieces
Heating System	Front & rear banks of quartz infra-red heating elements Element size: 247 x 62mm Element power: 400W Total elements per heater bank: 243 Element distribution: 9 wide x 27 high Number of heating zones: 243 (each containing 1 front & 1 rear element) Zone control: Software controlled Power: 0 – 100% in 5% increments Maximum power rating: 194.4 kW
Sheet Carrier	Drive: AC motor & gearbox with rack & pinion Control: Inverter Sheet clamping: Pneumatically operated by footswitch
Mould Table Movement	By hydraulic power through mechanical gearing Power-pack motor rating: 3kW Maximum pressure: 3000psi
Vacuum System	Vacuum pump motor rating (when supplied): 5.5kW Vacuum pump flow rate: 250m ³ /hr
Product cooling	By cooling fans with directional adjustment Number of fans per station: 12 Fan motor rating: 150W Fan flow rate: 425m ³ /hr
Mould Heating Facility	Power rating (when supplied): 9kW On/Off timer from control system
Control System	PLC controlled sequence. Touch screen user interface. Modem for remote diagnostic interrogation.

Compressed Air	Minimum pressure: 5.5 Bar Dry filtered supply
Electricity	3 Phase supply + Neutral + Earth: 380/415V @ 50Hz Maximum power consumption: 212kW
<i>example specification only - specification may be subject to change without notice</i>	

For further information contact

Armour Plastics Limited

Engineering Division
Pattinson Industrial Estate
Washington, Tyne & Wear, NE38 8QH, England

Telephone: +44 (0)191 416 7786 Fax: +44 (0)191 416 7109

sales@armour-engineering.com
www.armour-engineering.com